



**PUBLISHED TO RECORD
THE UPS AND DOWNS
OF THE
KANSAS SOARING ASSOCIATION**

Editor: Tony Condon

Volume LVII

May 2017

Number 5

PRESIDENT – TONY CONDON (2017-2018)

SECRETARY/TREASURER – BRIAN SILCOTT (2017-2018)

VICE PRESIDENT EAST – BOB BLANTON (2017-2018)

VICE PRESIDENT WEST – BOB HINSON (2017-2018)

TOW PLANE MANAGER – STEVE LEONARD (2017-2018)

DIRECTORS:

ANDREW PETERS (PAST PRESIDENT)

BRIAN BIRD (2017-2018)

MATT GONITZKE (2017-2018)

DON JONES (2016-2017)

TIM DOUBLE (2016-2017)



KSA Merchandise from yawstring.com

KSA CALENDAR

May 13th - KSA Meeting - Cookout at Sunflower

May 14th - 20th - Region 7 - Albert Lea, MN

June 5th - 14th - 15 Meter, Open, Standard Nationals - Cordele, GA

June 10th - KSA Meeting - Cookout at Sunflower

June 21st - 30th - Club Class Nationals - Hobbs, NM

Jun 29th - July 16th - 2nd FAI World 13.5m Class Gliding Championship - Szatymas, Hungary

July 1st - 8th - US Junior Camp & Contest - Elmira, NY

July 2nd - 8th - 2nd Annual Junior Nationals - Harris Hill, Elmira, NY

July 3rd - 7th - Women's Seminar - Chilhowee Gliderport - Benton, TN

July 8th - KSA Meeting - Cookout at Sunflower

July 15th - Kansas Kowbell Klassic - Sunflower

July 18th - 27th - Region 10 Low Performance Contest - Midlothian, TX

August 1st - 10th - 18 Meter Nationals - Uvalde, TX

August 12th - KSA Meeting - Cookout at Sunflower

August 28th - September 2nd - Region 10 Championship - Waller, TX

September 24th - Adventurous Babes Society

October 1st - Adventurous Babes Society Rain Date

October 7th - EAA Fly-In Newton, KS

October 29th - Closing Day at Sunflower

Nov 26th - Dec 8th - 2nd FAI Pan-American Gliding Championships - Santa Rosa de Conlara, Argentina

Member Accomplishments

Robert Estagin earned his B & C badges in the 2-33

Matt Reese soloed the 2-33!

Tony Condon placed 8th at the Sailplane Grand Prix

Notes from the President

The Regular Season has begun! However there are still some holes in the line duty and towpilot schedule. Have a quick look at the schedule at the back of the newsletter. If you don't see your name, get signed up. You can sign up for line duty on the online schedule or coordinate through **Tim Double** at tjd5185@gmail.com . Towpilots coordinate with **Steve Leonard** at zuni228@yahoo.com.

April featured a very well attended and productive work day to kick off the season. We've had some good flying to go with it. We transition now to cookout meetings at Sunflower on the second Saturday. Let's coordinate on the Yahoo! Group to organize. Also remember that just because it isn't the second Saturday doesn't mean we can't light the grill and have a good debrief.

You might notice this months newsletter is a bit thin. Don't forget to send in your pictures and write up your interesting flights! abcondon@gmail.com

See you at Sunflower,

Tony



Work Day Scenes:

Good group gathered (left)

Tim Double, Aaron Maurer, and William Calderwood patch holes in the hangar (below)



Sunflower Seeds

April 16th: **Bob Hinson** made three flights in the Grob, towed by **Bob Holliday**.

April 22nd: **Tony Condon** towed. **Kirk Bittner** got checked out to tow and new member **Dave Wellbrock** started his towpilot checkout. **Michael Groszek**, **Tim Double**, and **Matt Gonitzke** each did three flights in the Grob. Last tow of the day was by **Kirk** towing **Tony & Dave** in the Grob.

April 23rd: **Steve Leonard** arrived early and mowed around the tower building. Thank You **Steve!** **Tony Condon**, **Tim Double**, **Robert Estagin**, and **Eddie Estagin** assembled the Ka-6. **Ben Sorenson** towed. **Steve** and **Jimmy Prouty** ran the line. **David Kennedy** did a few flights in the 2-33. **Brian Bird** assembled and flew his Libelle. **Tim** soared the Ka-6 for almost 2 hours. **Robert** and **Tony** had a 45 minute flight in the 2-33. **Tony** then flew the Cherokee. **Mike Orindgreff** self launched in F8. **Robert** went solo and stayed up over an hour, earning his B and C badge! **Brian Bird** got the 2-22 out for some flights with **Matt Reese**. **Ben Sorenson** transitioned from the front of the rope to the end for three 2-22 flights with **Kirk Bittner** taking over tow duty. **Brian** and **Matt** flew the 2-33 which culminated with **Matt** going solo! **Tony** and **J Riedl** flew a couple flights in the 2-22 and **Robert** ended the day with a final solo flight. Also seen were **Becky Cole**, **Jerry Martin**, **Brian Silcott**, and **Kevin Riedl**.



April 15th - At least **Don Jones & KC Alexander** (Pictured) and **Paul Sodamann** (Photographer) hauled a bunch of tires to the Sedgwick County clean up day. Thanks guys!

Nominations Sought for US Soaring Hall of Fame

The Hall of Fame recognizes individuals who have made the highest achievements in, or contributions to, the sport of soaring in the United States. The Hall of Fame is an institution of the SSA, which is administered by the National Soaring Museum.

Up to two candidates may be elected to the Hall of Fame each year. Any member of the SSA may submit an individual's name as a nominee to the National Soaring Museum for consideration. Each submission must be accompanied by a detailed statement setting out the achievements or contributions of the nominee justifying consideration for election to the Hall of Fame. Nominations submitted will be reviewed by a vetting board which will reduce the list of candidates in any year to not more than two. The Board of Directors of the SSA will vote on the persons on the list whose names, if approved, will be submitted for final approval by SSA Life Members and SSA members with 15 or more consecutive years of SSA membership.

Nominations, along with the detailed statement described above, must be received by the National Soaring Museum.

The long-standing defining statement is "The United States Soaring Hall of Fame, created in 1954, recognizes individuals who have made the highest achievements in, or contributions to, the sport of soaring in the United States of America."

Expanding on the underlined words:

Soaring: the achievements/contributions must be in the sport of soaring.

Fame: the individual must be widely recognized in the soaring community.

Individuals: only an individual (one person) may qualify for nomination. Two or more persons sharing achievements/contributions must be nominated separately.

Highest achievements in or contributions to: the achievements/contributions must be of outstanding significance. A single achievement or contribution is not sufficient - it must be achievements or contributions - note the use of the plural.

United States of America: the achievements/contributions must have nationwide significance in the United States of America.

A nominee's achievements/contributions must be (or have been) long-lasting for the sport of soaring in the United States.

Achievements/contributions as part of a substantial financial interest, or as part of compensated service to the SSA or its affiliates, are not qualifiers for the Hall of Fame. Routine and/or long-time voluntary efforts (such as service as instructors, tow pilots, committee members, contest helpers, etc.) may be considered as only ancillary to the prerequisite of highest achievements/contributions.

Please send nominating letters and support material to:

Trafford L. Doherty
Director, National Soaring Museum
51 Soaring Hill Drive
Elmira, NY 14903-9204

Questions? Please call (607) 734-3128.

Email: director@soaringmuseum.org

Nomination letters and support documents (10 copies) should be submitted in a single mailing. Please do not ask others to send support letters separately - they should all be included with the nominating letter. **Nomination deadline is June 30th.**

FIGURE 2

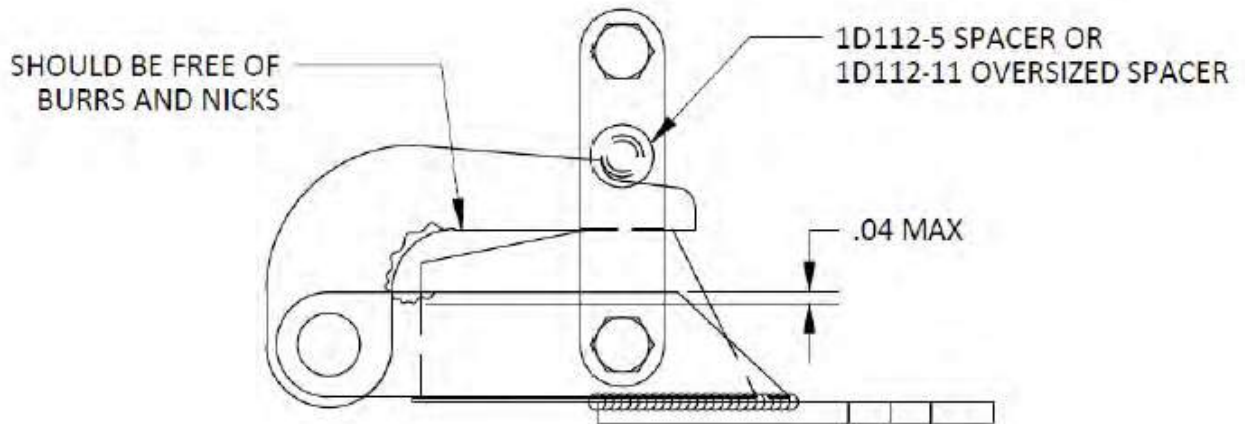
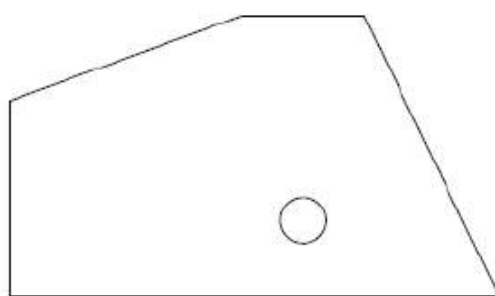
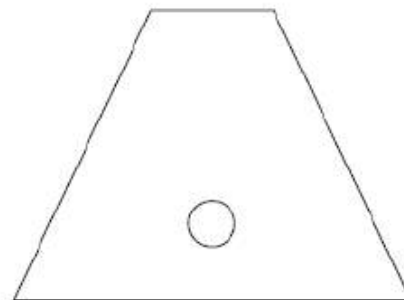

FIGURE 3



**10186-1 RUBBER
ACCEPTABLE***



**1D112-6/-12 RUBBER
UNACCEPTABLE**

* Rubber should not be notched. Tow ring should compress into rubber when tow hook assembly is latched

TABLE 2 – DAILY, 100-HOUR, & ANNUAL INSPECTION

	Daily	100 Hour	Annual	Installation
Visually inspect release arm for damage, cracks, deformation, and freedom of movement on pivot bolt.	X	X	X	X
Inspect rubber for excessive cracking, wear, or deformation. Verify correct rubber configuration per Figure 3		X	X	X
Visually and physically inspect release arm & rubber for excessive wear which would allow the tow hook to engage beyond hook step.	X	X	X	X
Visually check tow hook for damage, cracks, deformation, and freedom of movement on pivot bolt.	X	X	X	X
Inspect tow hook pivot joint by displacing the tow hook laterally. Tow hook should not be able to be displaced outside the outer face of the release arm assembly.		X	X	X
Perform a release check for proper release tension in accordance with Figure 1.			X	X
Test 1, 600 lb. Load				X
Test 2, 0 (zero) lb. Load		X	X	X

RULES FOR KSA FLYING AWARDS, 2017

Unless otherwise noted, the following applies to all awards:

For definition of bold terms, refer to the FAI Sporting Code Section 3-Gliding.

Awards are to be made for SOARING PERFORMANCES with a START POINT in the state of Kansas.

On distance and speed flights, the maximum LOSS OF HEIGHT allowed is 1000 meters (3281 feet)

For sailplanes without a SSA handicap, a handicap will be established by the KSA Board of Directors.

If disposable ballast is on board at takeoff, any handicap will be further multiplied by .92.

Flight documentation shall be submitted in .igc format

Task Declarations may be electronic, written, or verbal

TURNPOINTS will be attained by entering an OBSERVATION ZONE

Wooden Wings

The Wooden Wings Trophy is awarded for the longest distance SOARING PERFORMANCE in a wooden winged sailplane. The task may be FREE DISTANCE or 3 TURN POINT DISTANCE.

If the COURSE is abandoned before all TURNPOINTS are achieved, the flight will be scored as the distance for the achieved TURNPOINTS, plus the distance to the next declared TURNPOINT, minus the distance from the FIX establishing a landing or starting of a MoP to the next attempted TURNPOINT, but not less than the distance to the last achieved TURNPOINT.

Mamie Cup

The Mamie Cup is awarded for the longest distance SOARING PERFORMANCE of the year. The task may be FREE DISTANCE or 3 TURN POINT DISTANCE.

If the COURSE is abandoned before all TURNPOINTS are achieved, the flight will be scored as the distance for the achieved TURNPOINTS, plus the distance to the next declared TURNPOINT, minus the distance from the FIX establishing a landing or starting of a MoP to the next attempted TURNPOINT, but not less than the distance to the last achieved TURNPOINT.

KSA Flying Horse (Silver)

The KSA Flying Horse Trophy is awarded for the highest speed achieved around a CLOSED COURSE with a maximum of two declared TURNPOINTS and OFFICIAL DISTANCE of at least 100km and less than 200km.

Dennis Brown Memorial

The Dennis Brown Memorial Trophy is awarded for the highest speed achieved around a CLOSED COURSE with a maximum of two declared TURNPOINTS and OFFICIAL DISTANCE of at least 200km and less than 300km.

KSA Flying Horse (Gold)

The KSA Flying Horse Trophy is awarded for the highest speed achieved around a CLOSED COURSE with a maximum of two declared TURNPOINTS and OFFICIAL DISTANCE of at least 300km.

Curt McNay Pilot of the Year

The Curt McNay Pilot of the Year Trophy is awarded for the best combined score in four tasks - DURATION (6 hours maximum), GAIN OF HEIGHT, Handicapped Distance, and Handicapped Speed. Each task will be scored from a different SOARING PERFORMANCE.

The Distance task may be FREE DISTANCE or 3 TURN POINT DISTANCE.

If the COURSE is abandoned before all TURNPOINTS are achieved, the flight will be scored as the distance for the achieved TURNPOINTS, plus the distance to the next declared TURNPOINT, minus the distance from the FIX establishing a landing or starting of a MoP to the next attempted TURNPOINT, but not less than the distance to the last achieved TURNPOINT.

The speed task must be a CLOSED COURSE with an OFFICIAL DISTANCE of at least 100 KM. However, a 3 TURN POINT DISTANCE of at least 200 KM may be used if you are flying a sailplane with a handicap of 1.36 or greater. In this case, a wind correction factor of 15 MPH will be subtracted from the achieved speed prior to scoring.

1000 points will be awarded the best performance in each task. Each contestant's performance will be ratioed according to the best performance in the task being evaluated. The sum of each contestant's scores will be compared, the highest being the winner.

Charles Henning Award

The intent of this trophy is to encourage more people to fly cross country.

- 1) The cross country task will be a CLOSED COURSE with any number of TURNPOINTS.
- 2) Handicapped Speed will be determined by the DURATION or 2 Hours, whichever is greater.
- 3) There is no limit on start or finish altitude.
- 5) TURNPOINTS may be any TURNPOINT published in the KSA Turnpoint File or a public use airport marked on a Sectional Chart.
- 6) The winner will be determined by averaging the two best tasks of the year for each pilot. The averaging will be accomplished by adding the two speeds and dividing by 2.

Lead C

Awarded to the pilot or soaring supporter who makes the most noteworthy non-achievement during the calendar year.

Praying Mantis

The Praying Mantis is awarded to the pilot who makes the most significant advance in his or her soaring ability during the calendar year. To be eligible for this award, the pilot must not yet have his or her Silver Badge at the beginning of the calendar year. The Praying Mantis selection committee consists of the KSA President, WSA President, *Variometer* Editor, WSA Chief Instructor, and the SSA State Governor for Kansas.

Towing Operations

The Towing Operations trophy is awarded to the person making the most significant contribution to the operation of the KSA Towplanes for the year.

Maintenance Trophy

The Maintenance Trophy is awarded to the person making the greatest contribution via maintaining equipment related to soaring flight during the year.

Submit flights at

<http://www.soarkansas.org/soar/scoring.aspx>

KSA Schedule 2017

Date	Line Managers	Towpilot
Saturday, May 6	Robert Estagin 316-573-5881 Brian Silcott 620-204-0051	Tony Condon 515-291-0089
Sunday, May 7	Steve Leonard 316-249-7248	
Saturday, May 13	Dave Wilkus 316-706-9261 Matt Gonitzke 815-980-6944	
Sunday, May 14	Don Jones 620-960-6444 David Kennedy 316-841-2912	Jerry Boone 620-474-4177
Saturday, May 20	Brian Silcott 620-204-0051 Kevin Ganoung 785-536-4540	Paul Sodamann 785-456-5654
Sunday, May 21	Keith Smith 785-643-6817 Jimmy Prouty 316-305-5835	Bob Hinson 316-841-5561
Saturday, May 27	Alex Hunt 785-224-6330 Dave Wilkus 316-706-9261	
Sunday, May 28	Harry Clayton 316-644-9117 Sue Erlenwein 316-644-9117	
Monday, May 29 Memorial Day	Don Jones 620-960-6444	
Saturday, June 3	Jimmy Prouty 316-305-5835	Bob Blanton 316-841-2921
Sunday, June 4	David Kennedy 316-841-2912	
Saturday, June 10	Brian Silcott 620-204-0051	
Sunday, June 11	Tim Double 724-954-2938	
Saturday, June 17	Kevin Ganoung 785-536-4540	Mark Schlegel 316-641-5093
Sunday, June 18		Bob Blanton 316-841-2921
Saturday, June 24		Paul Sodamann 785-456-5654
Sunday, June 25	Steve Leonard 316-249-7248 Leah Condon 316-249-3535	Bob Hinson 316-841-5561

<https://www.brownbearsw.com/cal/ksa>

Need a towpilot? Call **Kirk Bittner** 860-670-5544

KSA TOWCARD

TOW NUMBER START TACH TIME

TOW PILOT _____

PILOT: _____

ADDRESS: _____

SAILPLANE: _____

TOW HEIGHT: _____

TOW SPEED (MPH): _____

DATE: _____

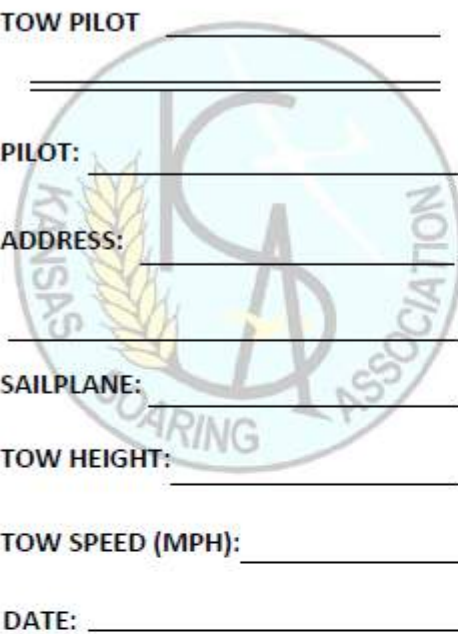

KSA TOWCARD

TOW NUMBER START TACH TIME

TOW PILOT _____

PILOT: _____

ADDRESS: _____

SAILPLANE: _____

TOW HEIGHT: _____

TOW SPEED (MPH): _____

DATE: _____

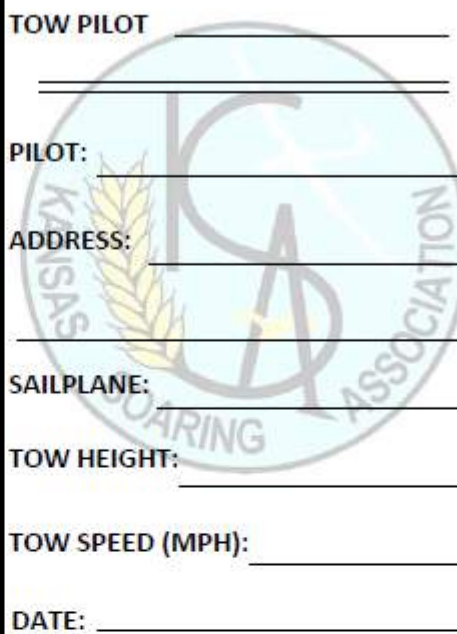

KSA TOWCARD

TOW NUMBER START TACH TIME

TOW PILOT _____

PILOT: _____

ADDRESS: _____

SAILPLANE: _____

TOW HEIGHT: _____

TOW SPEED (MPH): _____

DATE: _____

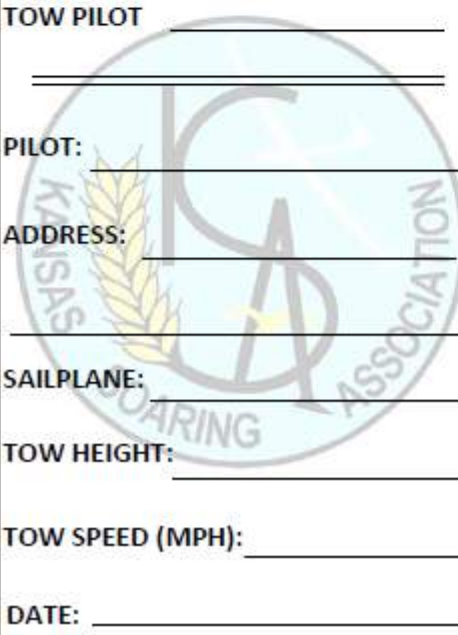

KSA TOWCARD

TOW NUMBER START TACH TIME

TOW PILOT _____

PILOT: _____

ADDRESS: _____

SAILPLANE: _____

TOW HEIGHT: _____

TOW SPEED (MPH): _____

DATE: _____

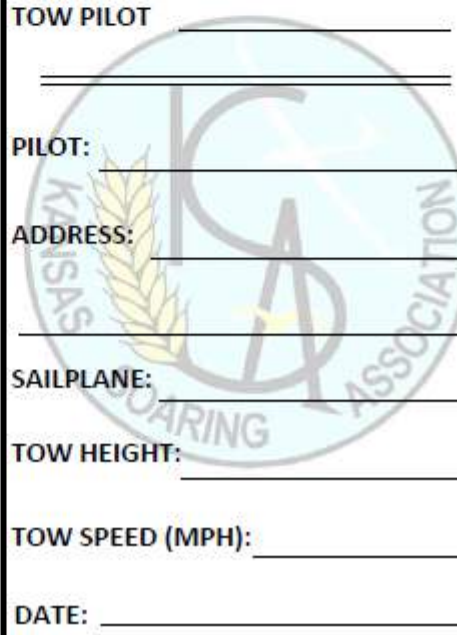

KSA VARIOMETER

911 N Gilman

Wichita, KS 67203

abcondon@gmail.com

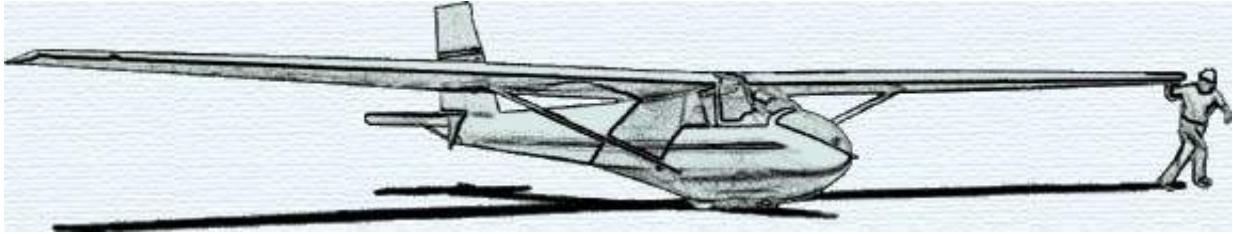

KSA Meeting
May 13th - After Flying
Cookout at Sunflower